

# Tomahawk and Knife Throwing Target Stand

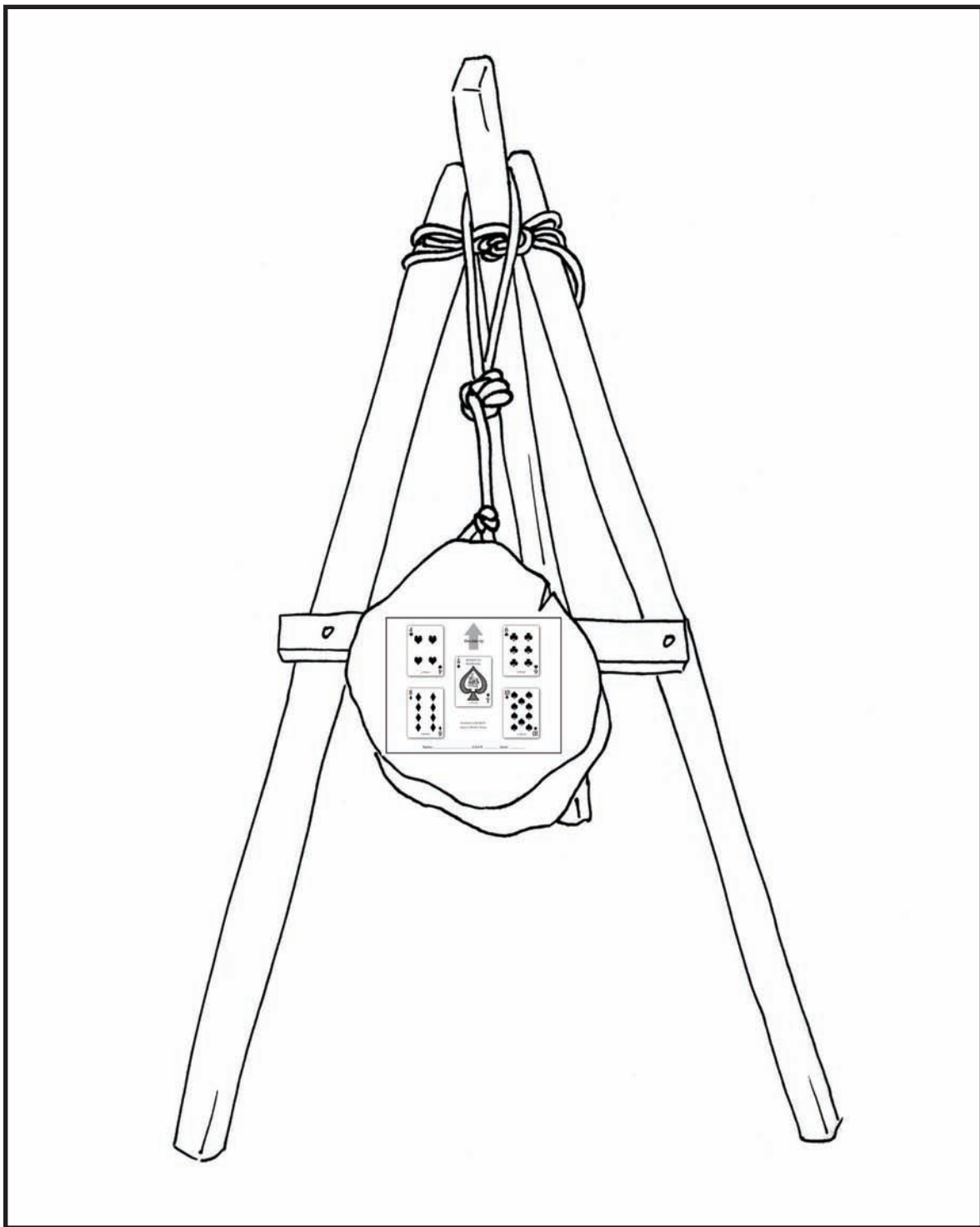

Instructions & Materials List

# Materials and Parts

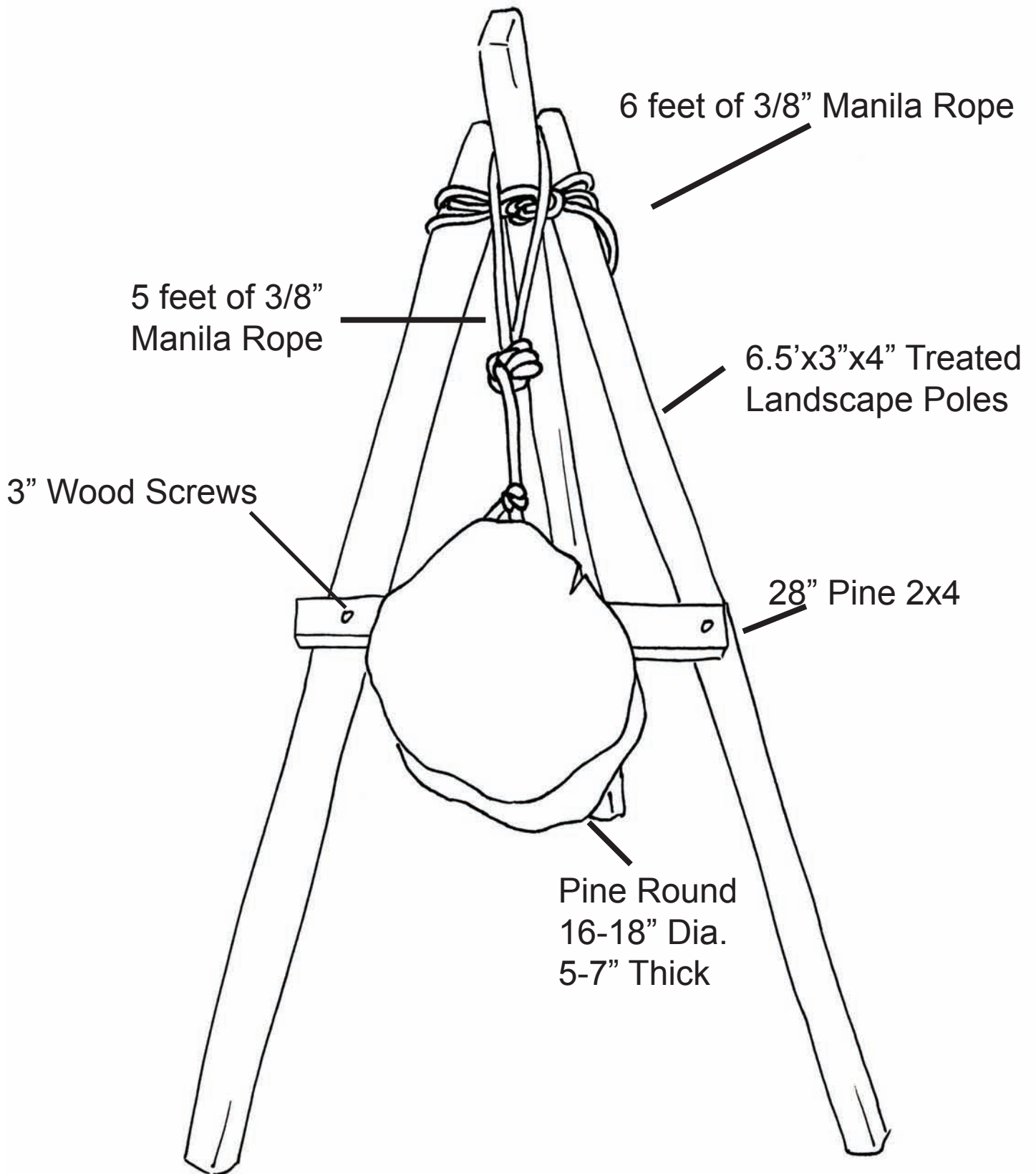

## Step 1.

Drill a 5/8" hole 5" from the top of two landscape poles. Drill a 5/8" hole 9" from the top of the third landscape pole.

(Figure 1).

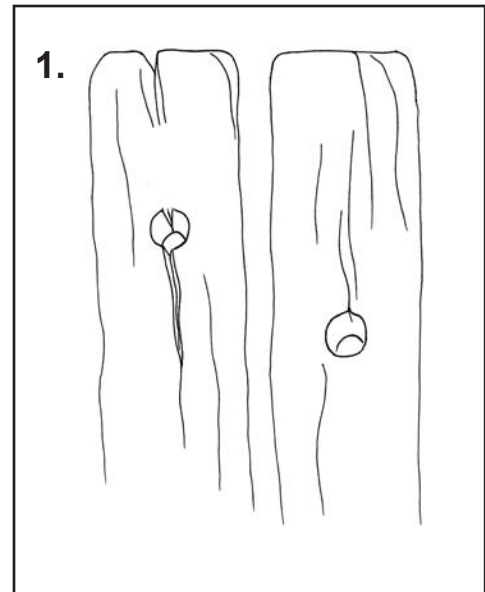

## Step 2.

Lay the three poles on their side with the two with the hole 5" from the top on the outside of the third pole and run the rope through the holes. Tie the rope loosely with a square knot. Leaving more of the rope on one side.

(Figure 2).

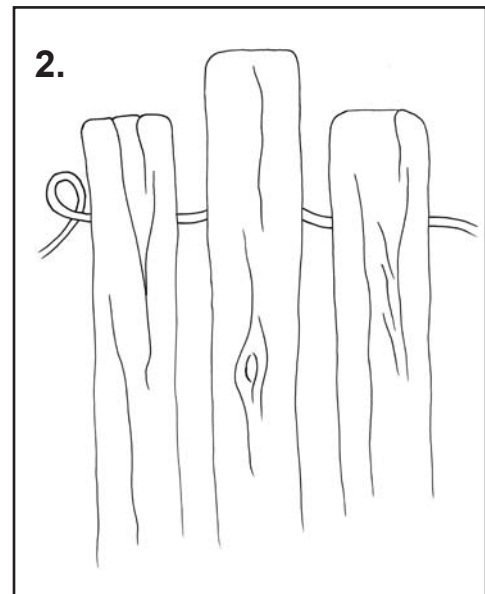

## Step 3.

Then stand the three poles upright and bring the outside poles forward and spread them apart. The center pole is pushed toward the back so that the top of it rests against the square knot. (see step #4)

(Figure 3).

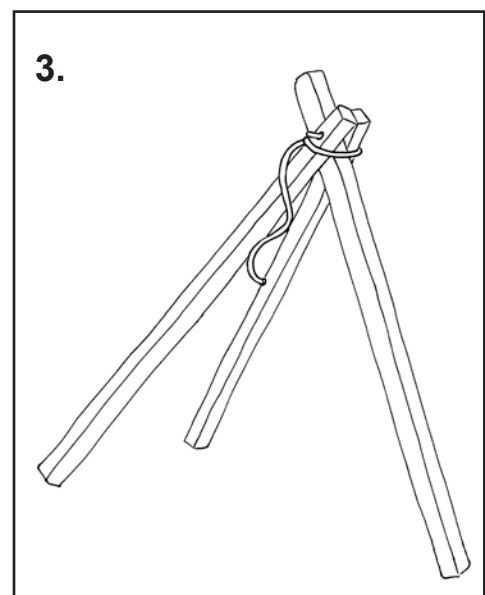

## Step 4.

The center pole should be resting on the square knot. The stand will be a little wobbly, and that is alright at this stage.

(Figure 4)

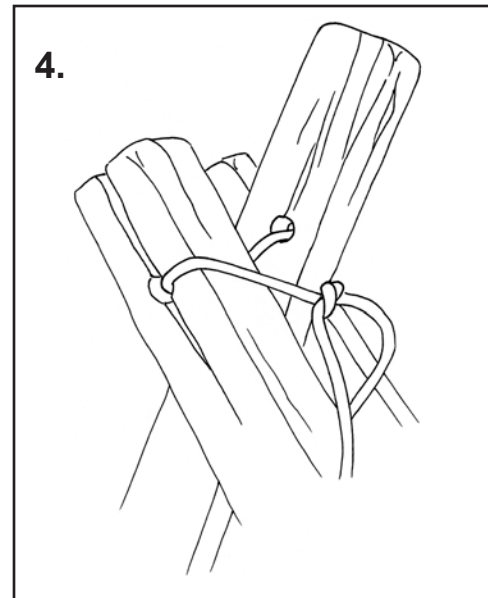

## Step 5.

After the poles are spread apart, bring the long end of the rope around the back of the tripod and tie tightly in the front with a second square knot.

(Figure 5 and 6)

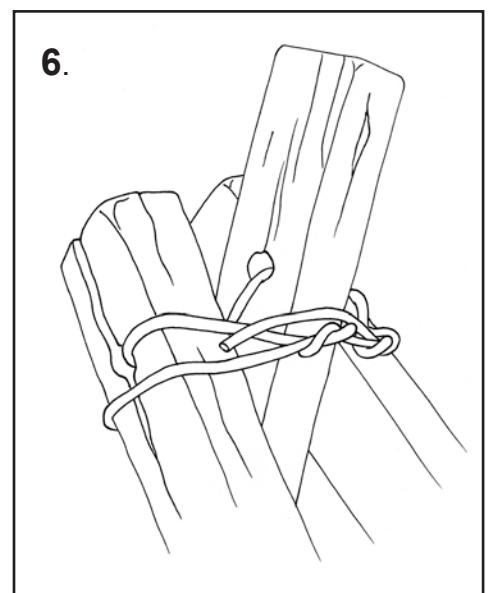
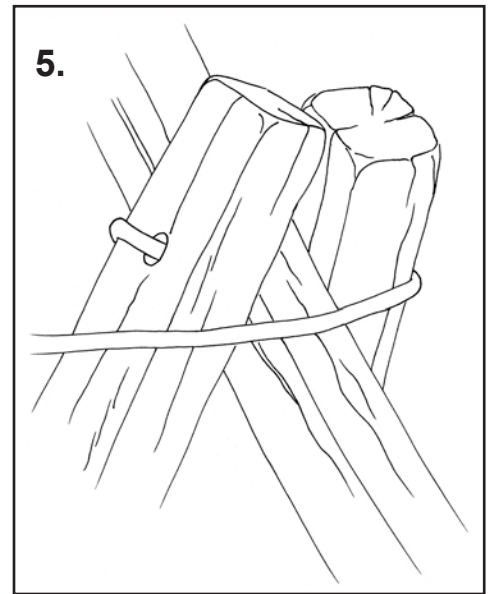

## Step 6.

Predrill the 2x4 cross piece 2" from each end. Then screw onto front legs using 3" wood screws. Put the crosspiece approximately 30" from the bottom of the legs.

(Figure 7)

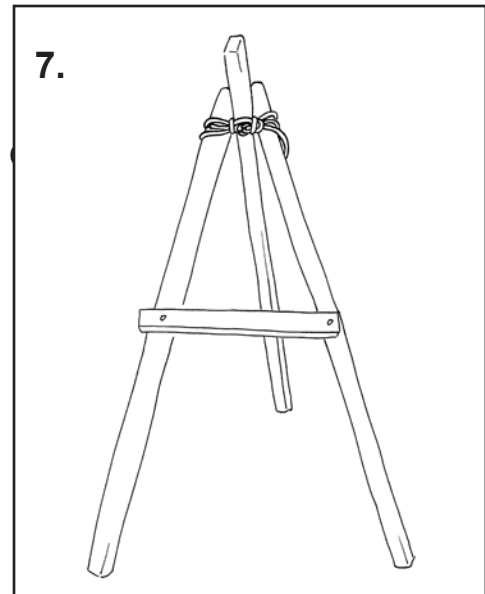

## Step 7.

Screw the eyebolt into the top of the target round. Attach one end of the 3/8" rope to the eyebolt using two half hitches. Then tie a tautline hitch on the opposite end of the rope.

(Figure 8)

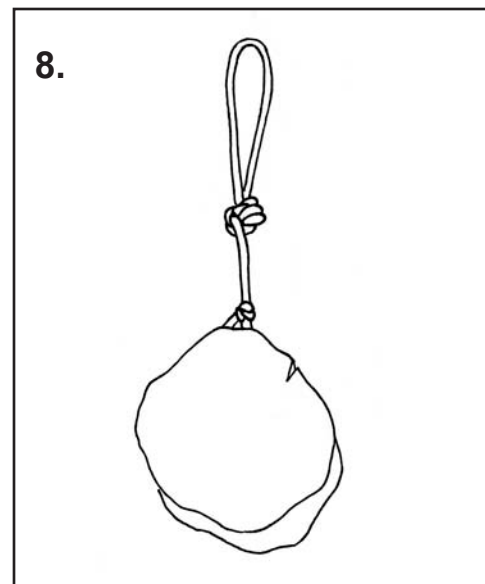

## Step 8.

Loop the end of the rope around the center pole. Loosen or tighten the tautline hitch until the target round is against the cross piece. The round should sit low enough on the cross piece so that the face is close to perpendicular to the ground. Attach target and start to throw!

(Figure 9)

